

Professional oven hinge

For door weights from 9 to 11kg

Applications

Professional oven
Catering cookers

Geometry

Footprint: W, H, L
Fulcrum position (respect to the base): X, Y
Parallel dimension (between base and receiver): Q

Technical features

Parallel dimension Q: 6-8-12mm
Fulcrum position X: 17mm
Footprint H: 32mm

Functionality

Balancing: usually balanced up to 45°. Cam custom design possible
Closing force: 30-70N based on application and customer needs.

Removability

By means of a releasing hook

Performance

Operating temperature: 130°C
Dynamic test: up to 10k cycles
High resistance to static load

Compliance

Compliant to VDE anti pinching

Receiver

Hole fixation spacing: 94mm
Roller: steel

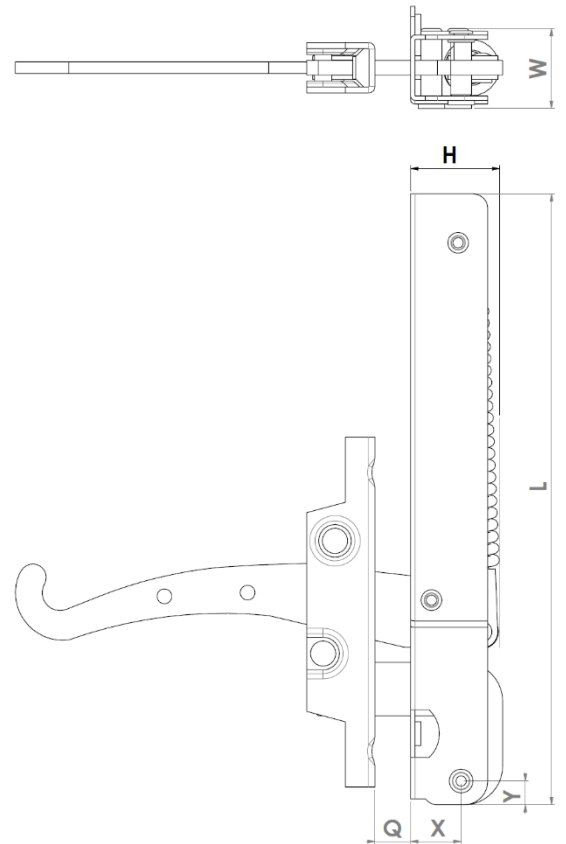

2D Drawing

✓
The following drawing shows the main functional dimensions.
Possibility of customized designs based on customer needs

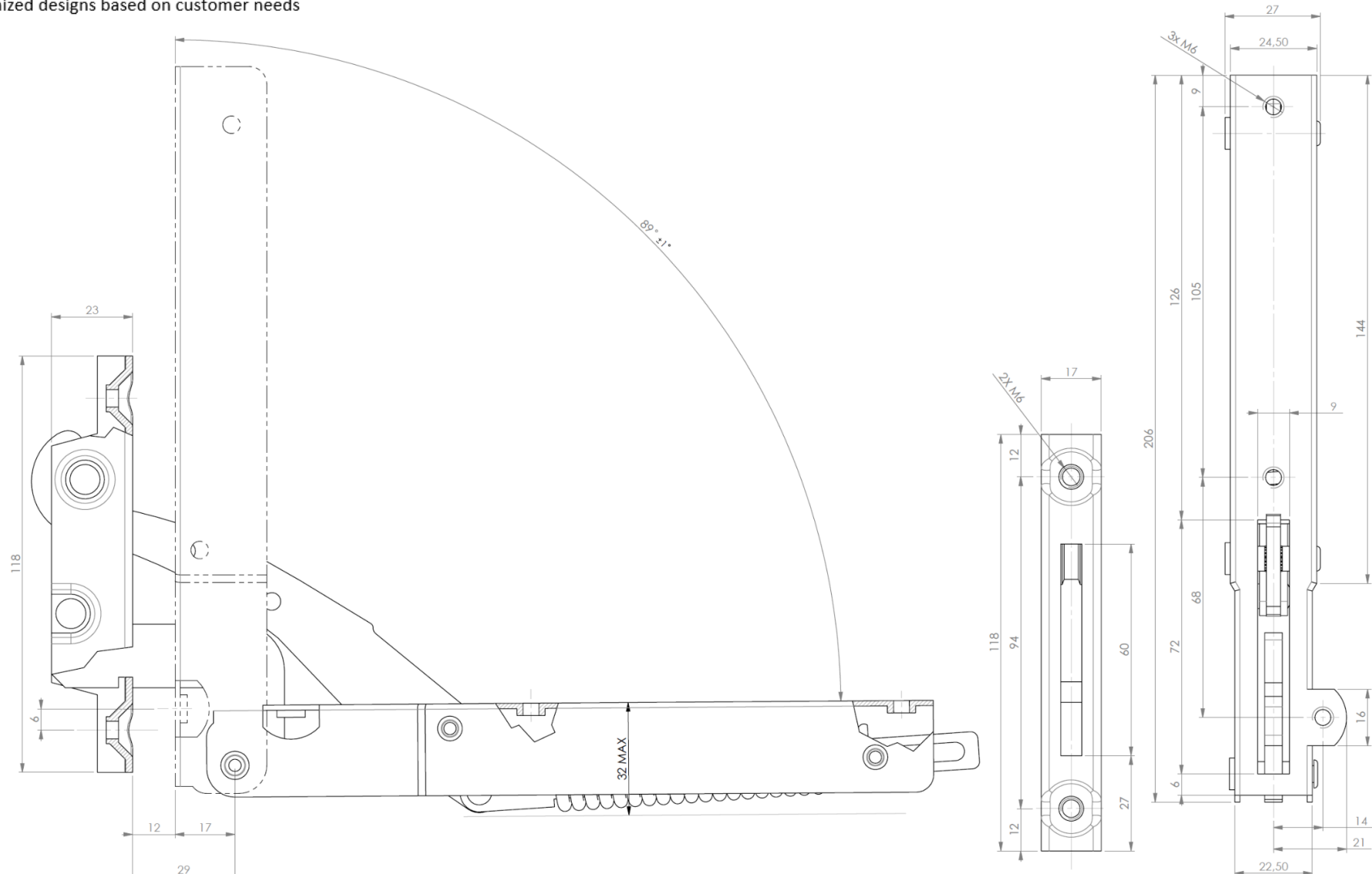

Stabilimento e Uffici Amministrativi: Via De Gasperi, 92 - 20010 Bareggio (MI) - Italia
Tel. +39 02 90 279 411 - Fax +39 02 90 279 499 - www.faringosi-hinges.it
Sede legale: Via Martiri della libertà, 66 - 25035 Ospitaletto (BS) - Italia