

# Hidden cam hinge fixed fulcrum

For door weights from 12kg to 20kg

## Applications

Built in oven  
 Microwave oven  
 Cooker

## Geometry

**Footprint:** W, H, L  
**Fulcrum position (respect to the base):** X, Y  
**Parallel dimension (between base and receiver):** Q  
**Front frame – receiver distance:** K

## Technical features

**Fulcrum position** X=21mm Y=9mm  
**Parallel dimension Q:** 14mm  
**Footprint B:** 28.5mm  
**Fixing:** top or front

## Functionality

**Balancing:** 0°-88°  
**Closing force:** 30-70N based on application and customer needs.  
**Broil position:** available

## Removability

By means of holes on arm at open door

## Performance

**Operating temperature:** 130°C  
**Static load:** up to 80lb (36.5kg)  
**Dynamic test:** up to 25.000 cycles (100.000 for microwave applications)

## Compliance

Compliant to VDE anti pinching

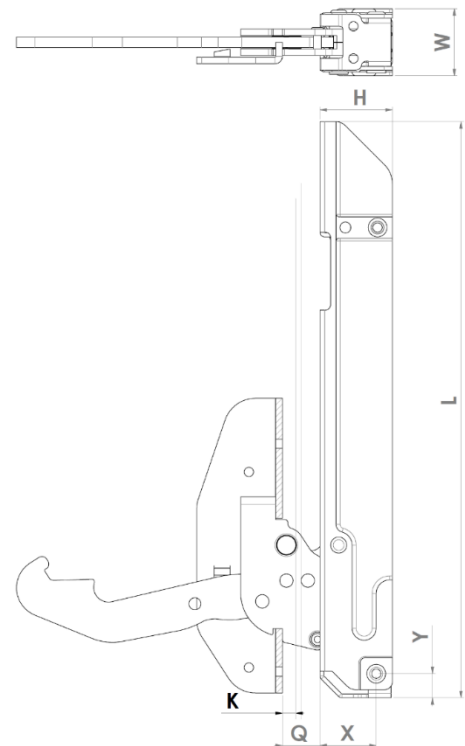

## Receiver

**Hole fixation spacing:** 85mm  
**Side fixation available**  
**Custom receiver possible based on customer needs**

*2D Drawing*

✓  
The following drawing shows the main functional dimensions.  
Possibility of customized designs based on customer needs

